

WIRE COMBINATION CHART
FOR WIRE JOINT J216-410

NOTES:

1. FOR #16-#10 AWG SOLID OR STRANDED COPPER WIRE (SEE WIRE COMBINATION CHART)
2. TWIST WIRES TOGETHER BEFORE ASSEMBLING TO WIRE JOINT
3. MATERIAL: COPPER COATED STEEL WITH TIN PLATING
4. RECOMMENDED CRIMP TOOLS: CT-100, CT-200 (TWO CRIMPS REQUIRED)
5. STRIP LENGTH $3/4" \pm 1/16"$ - 0"

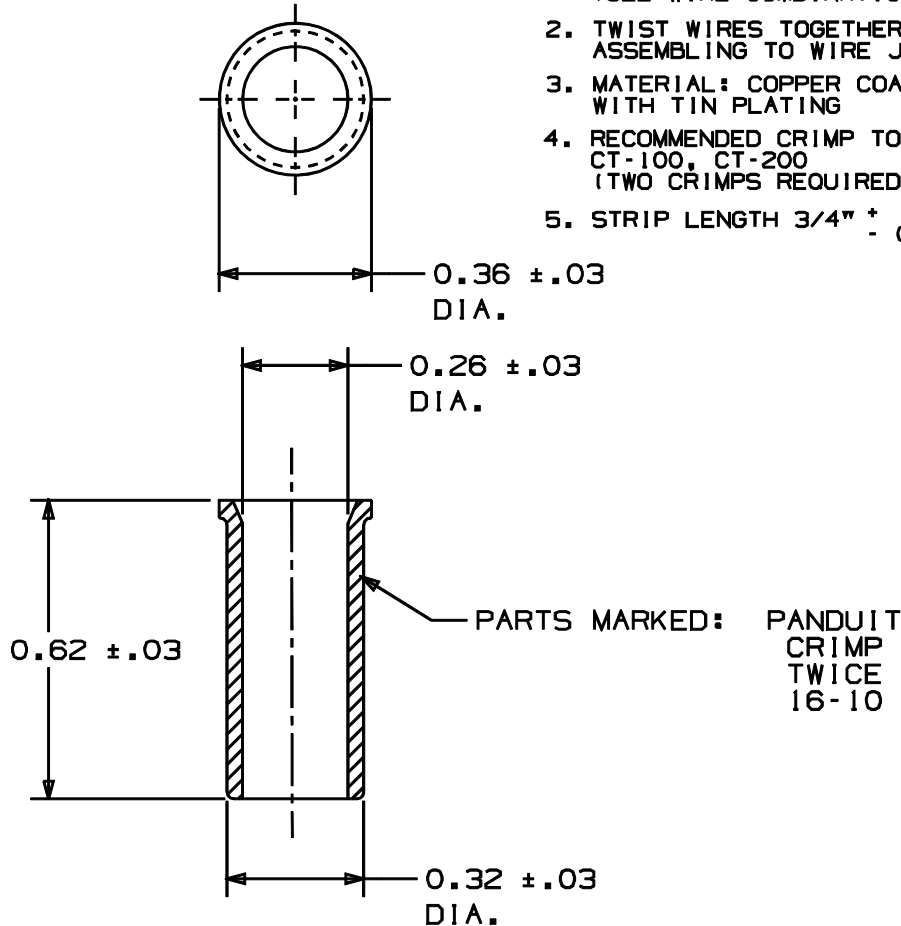

WIRE SIZE	NUMBER OF WIRES	NUMBER OF ADDITIONAL WIRES OF ONE SIZE			
		#16 AWG	#14 AWG	#12 AWG	#10 AWG
#16 AWG	1	1 TO 8	1 TO 5	1 TO 4	1 TO 3
	2	1 TO 7	1 TO 4	1 TO 4	1 TO 3
	3	1 TO 6	1 TO 4	1 TO 3	1 OR 2
	4	1 TO 5	1 TO 3	1 TO 3	1 OR 2
	5	1 TO 4	1 TO 3	1 OR 2	1
	6	1 TO 3	1 OR 2	1 OR 2	1
	7	1 OR 2	1	1	0
	8	1	0	0	0
#14 AWG	1	1 TO 7	1 TO 5	1 TO 4	1 TO 3
	2	1 TO 6	1 TO 4	1 TO 3	1 OR 2
	3	1 TO 5	1 TO 3	1 OR 2	1 OR 2
	4	1 TO 3	1 OR 2	1 OR 2	1
	5	1	1	1	0
#12 AWG	1	1 TO 7	1 TO 5	1 TO 4	1 TO 3
	2	1 TO 6	1 TO 4	1 TO 3	1 OR 2
	3	1 TO 4	1 OR 2	1 OR 2	1
	4	1 OR 2	1	1	1
#10 AWG	1	1 TO 6	1 TO 4	1 TO 4	1 TO 3
	2	1 TO 4	1 TO 3	1 OR 2	1 OR 2
	3	1 OR 2	1	1	1

CIRCULAR MIL RANGE 5160-41600

A41006_02

02	1/01	SAB		FILE SPEC. WAS N41006AA_PCD_01					 TINLEY PARK, ILLINOIS NON-INSULATED WIRE JOINT J216-410		
01	11/95	ED		REVISED & REDRAWN ON CAD							
00	3/83	KBL	LA	DRAWING RELEASED		LA	KS				
REV	DATE	BY	CHK	DESCRIPTION	ECN #	APP	PM	DRAWN BY ED	CHK'D	SCALE	DRAWING NO. A41006